

8.7 Replacing Membrane Switch Panel

- a) To remove the membrane switch panel, the control and display PC-boards must first be removed from the front housing section
- b) The defective membrane switch panel is lifted at one corner with a knife and pulled off.
- c) Remove remaining glue and any unevenness (use an adhesive solvent, not a plastic solvent)
- d) Remove protective backing from new membrane switch panel, guide cables through opening in housing, and align panel without pressure.
- e) When pressing membrane switch panel into place, avoid excessive pressure on touch buttons and display window.

Assembly:

Assembly takes place in reverse sequence.

8.8 Replacing upper electronic head P.C. Board

Display Board

- Connect the connector for the membrane switch panel
- Check positions of the LED's; if bent, correct position.

Insertion of control PC-board:

- Align SET/RUN knob properly with flattened shaft.

Assembling halves of housing:

- Avoid pinching of cables.

CHAPTER 9

Servicing Lower Motor Unit

Note: The upper control head and the lower motor unit are integrated on the ATL-2,3. In order to separate them you must first remove the access panel in front and disconnect the power cable and the data ribbon cable.

- | | |
|-----|----------------------------|
| 9.1 | Removal |
| 9.2 | Pump Repair |
| 9.3 | Exploded Drawing |
| 9.4 | Rotation Motor Replacement |
| 9.5 | Heating Element Removal |
| 9.6 | Circuit Board Removal |
| 9.7 | Temperature Calibration |
| 9.8 | Hose Replacement |
| 9.9 | Sensor Replacement |

9.1 Removal

Removal of Motor Unit

- Raise lift arm to 45 degree position
- remove brass machine screws

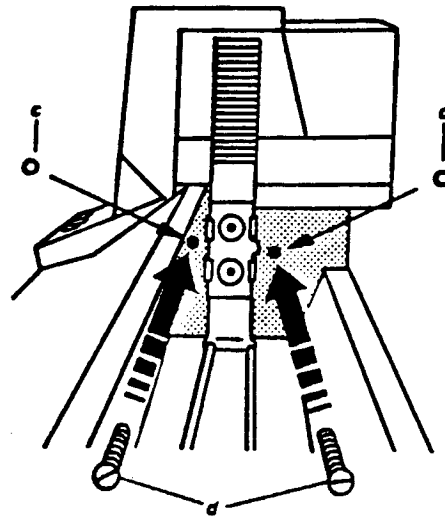

- Bend away clamp (07098) and tilt top assembly to the right into the trough.

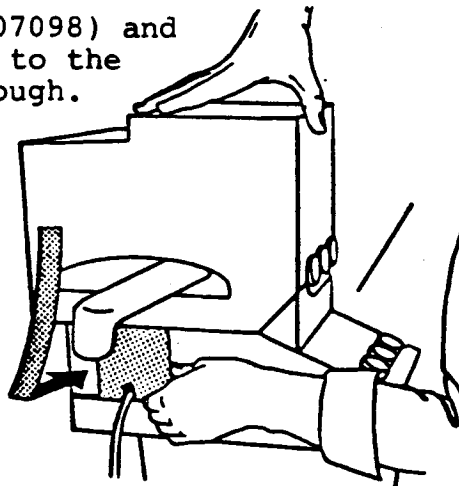

ATL-3

- loosen locking screw for ATL 3 bottom cabinet door.
- Open door, pull motor unit power cable out of terminal strip. On full size ATL only.
- Unscrew 6 Allen screws with special wrench (16153) (Provided)
- Remove motor unit.

9.1 Page 2

ATL-2

-Remove four thumb nuts
on underside of water trough
at four corners of motor unit
to release unit.

PUMP REPAIR

The Pump consists of three major sections, an A.C. motor, and impeller shaft, and a hollow "pump housing".

A.C. current is applied to the pump motor through a relay controlled lower float switch. This switch also supplies power to the heating element.

The temperature probe is located inside the pump housing next to and parallel to the impeller shaft. It is important to treat this probe with care while working on the pump.

Common Problems

1. Dirt and / or lint on the pump impeller (picked up from tempering bath) will often slow down or stop the rotation of the impeller. It is important to periodically clean this assembly. Instructions for this process can be found in the Instruction Manual (See section of this manual with instructions.)
2. The bottom part of the impeller is a pin which rotates in a hole in the "pump housing" (Part# 06017) Occasionally, "flashing" from the plastic molding process can remain in the hole of the "pump housing" causing it to slow or stop rotation of the impeller. The hole should be cleared with a 4.5mm drill bit to remove any resistance to rotation.
3. The "pump housing" snaps into the bottom of the motor unit housing. It is possible, particularly during transit or reassembly after cleaning, to knock this housing

9.2 Page 2

out of alignment. Symptoms will range from a "noisy" pump to failure of the impeller to rotate. The solution is simply pushing the housing back into it's opening until it snaps into place.

Servicing

Pry off pump impeller with offset needle nose pliers to replace pump impeller (95081) or pump motor (32008)

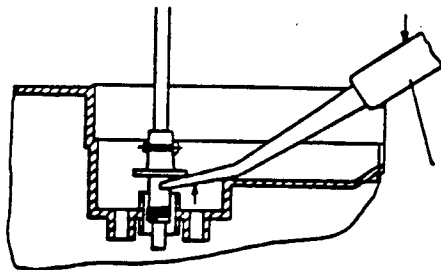

Pry up with angular pliers.

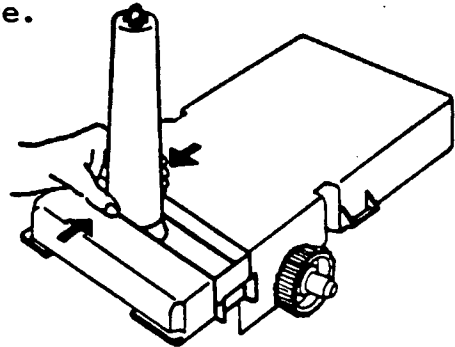

- To remove pump motor
- Remove the six Philipps screws shown in drawing
- Remove upper housing of motor unit
- Remove pump motor screws and remove motor
- Installation of pump motor
- Position felt disc on motor shaft and soak with non-detergent oil.
- Screw motor on so that it contacts the support on the bottom housing uniformly (if motor is installed at an angle pump impeller will run off center)

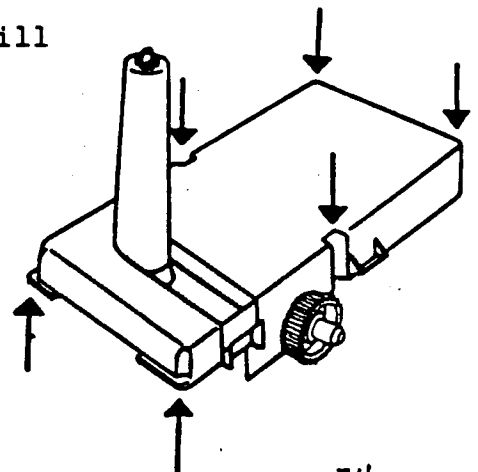

9.2 Page 3

- To install pump impeller (95081)
press down completely with off-
set needle nose pliers

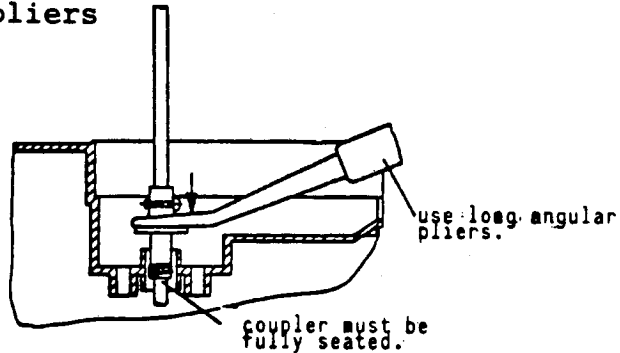

- To install the pump housing (06017)
- All 4 lugs must engage correctly and the shaft must be positioned in the center hole Caution! If the shaft is not pressed down completely the pump vanes can hit against the housing. Minimum distance between pump vanes and housing 3mm

Technical data: Motor
FRG 220 V AC;
GB: 240 V AC;
USA:120 V AC
P=10 Watts
Speed: 2750 rpm

9.3 Servicing Lower Motor Unit

- Interface board, motor unit (94015)
- Transformer board, motor unit (94016)

If work is required on the lower motor control unit,

- remove the four Philipps screws shown in drawing
- remove 3 knobs by pulling straight off
- remove front panel

Exploded drawing, motor unit (95311/95289)

